

# DATA SHEET

**SA5219**

Wideband variable gain amplifier

Product specification  
Replaces data of 1993 Dec 10  
IC17 Data Handbook

1997 Nov 07

**Philips Semiconductors**



**PHILIPS**

# Wideband variable gain amplifier

# SA5219

## DESCRIPTION

The SA5219 represents a breakthrough in monolithic amplifier design featuring several innovations. This unique design has combined the advantages of a high speed bipolar process with the proven Gilbert architecture.

The SA5219 is a linear broadband RF amplifier whose gain is controlled by a single DC voltage. The amplifier runs off a single 5 volt supply and consumes only 40mA. The amplifier has high impedance (1k $\Omega$ ) differential inputs. The output is 50 $\Omega$  differential. Therefore, the 5219 can simultaneously perform AGC, impedance transformation, and the balun functions.

The dynamic range is excellent over a wide range of gain setting. Furthermore, the noise performance degrades at a comparatively slow rate as the gain is reduced. This is an important feature when building linear AGC systems.

## FEATURES

- 700MHz bandwidth
- High impedance differential input
- 50 $\Omega$  differential output
- Single 5V power supply
- 0 - 1V gain control pin
- >60dB gain control range at 200MHz
- 26dB maximum gain differential
- Exceptional  $V_{CONTROL} / V_{GAIN}$  linearity
- 7dB noise figure minimum
- Full ESD protection
- Easily cascadable

## ORDERING INFORMATION

Description	Temperature Range	Order Code	DWG #
16-Pin Plastic Small Outline (SO) package	-40 to +85 $^{\circ}$ C	SA5219D	SOT109-1
16-Pin Plastic Dual In-Line package (DIP)	-40 to +85 $^{\circ}$ C	SA5219N	SOT38-4

## PIN CONFIGURATION

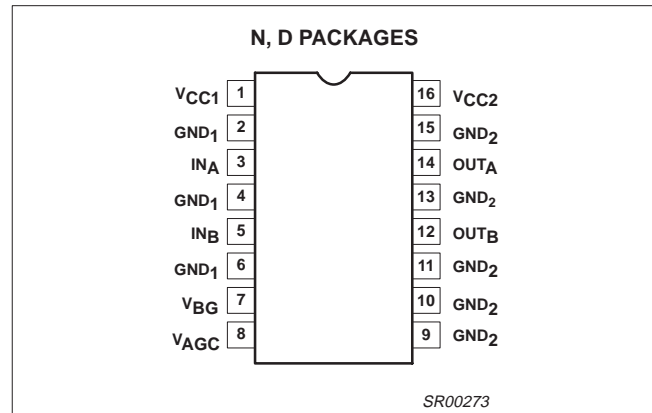

Figure 1. Pin Configuration

## APPLICATIONS

- Linear AGC systems
- Very linear AM modulator
- RF balun
- Cable TV multi-purpose amplifier
- Fiber optic AGC
- RADAR
- User programmable fixed gain block
- Video
- Satellite receivers
- Cellular communications

## Wideband variable gain amplifier

SA5219

## ABSOLUTE MAXIMUM RATINGS

SYMBOL	PARAMETER	RATING	UNITS
$V_{CC}$	Supply voltage	-0.5 to +8.0	V
$P_D$	Power dissipation, $T_A = 25^\circ\text{C}$ (still air) <sup>1</sup> 16-Pin Plastic DIP 16-Pin Plastic SO	1450 1100	mW mW
$T_{JMAX}$	Maximum operating junction temperature	150	$^\circ\text{C}$
$T_{STG}$	Storage temperature range	-65 to +150	$^\circ\text{C}$

## NOTES:

1. Maximum dissipation is determined by the operating ambient temperature and the thermal resistance,  $\theta_{JA}$ :  
 16-Pin DIP:  $\theta_{JA} = 85^\circ\text{C/W}$   
 16-Pin SO:  $\theta_{JA} = 110^\circ\text{C/W}$

## RECOMMENDED OPERATING CONDITIONS

SYMBOL	PARAMETER	RATING	UNITS
$V_{CC}$	Supply voltage	$V_{CC1} = V_{CC2} = 4.5$ to $7.0\text{V}$	V
$T_A$	Operating ambient temperature range SA Grade	-40 to +85	$^\circ\text{C}$
$T_J$	Operating junction temperature range SA Grade	-40 to +105	$^\circ\text{C}$

## DC ELECTRICAL CHARACTERISTICS

$T_A = 25^\circ\text{C}$ ,  $V_{CC1} = V_{CC2} = +5\text{V}$ ,  $V_{AGC} = 1.0\text{V}$ , unless otherwise specified.

SYMBOL	PARAMETER	TEST CONDITIONS	LIMITS			UNIT
			MIN	TYP	MAX	
$I_{CC}$	Supply current	DC tested	36	43	50	mA
$A_V$	Voltage gain (single-ended in/single-ended out)	DC tested, $R_L = 10\text{k}\Omega$	16	19	22	dB
$A_V$	Voltage gain (single-ended in/differential out)	DC tested, $R_L = 10\text{k}\Omega$	22	25	28	dB
$R_{IN}$	Input resistance (single-ended)	DC tested at $\pm 50\mu\text{A}$	0.8	1.2	1.6	$\text{k}\Omega$
$R_{OUT}$	Output resistance (single-ended)	DC tested at $\pm 1\text{mA}$	35	60	80	$\Omega$
$V_{OS}$	Output offset voltage (output referred)			$\pm 20$	$\pm 150$	mV
$V_{IN}$	DC level on inputs		1.6	2.0	2.4	V
$V_{OUT}$	DC level on outputs		1.9	2.4	2.9	V
PSRR	Output offset supply rejection ratio		18	45		dB
$V_{BG}$	Bandgap reference voltage	$4.5\text{V} < V_{CC} < 7\text{V}$ $R_{BG} = 10\text{k}\Omega$	1.2	1.32	1.45	V
$R_{BG}$	Bandgap loading		2	10		$\text{k}\Omega$
$V_{AGC}$	AGC DC control voltage range			0-1.3		V
$I_{BAGC}$	AGC pin DC bias current	$0\text{V} < V_{AGC} < 1.3\text{V}$		-0.7	-6	$\mu\text{A}$

## Wideband variable gain amplifier

SA5219

**AC ELECTRICAL CHARACTERISTICS**T<sub>A</sub> = 25°C, V<sub>CC1</sub> = V<sub>CC2</sub> = +5.0V, V<sub>AGC</sub> = 1.0V, unless otherwise specified.

SYMBOL	PARAMETER	TEST CONDITIONS	LIMITS			UNIT
			MIN	TYP	MAX	
BW	-3dB bandwidth			700		MHz
GF	Gain flatness	DC - 500MHz		±0.4		dB
V <sub>IMAX</sub>	Maximum input voltage swing (single-ended) for linear operation <sup>1</sup>			200		mV <sub>p-p</sub>
V <sub>OMAX</sub>	Maximum output voltage swing (single-ended) for linear operation <sup>1</sup>	R <sub>L</sub> = 50Ω		400		mV <sub>p-p</sub>
		R <sub>L</sub> = 1kΩ		1.9		V <sub>p-p</sub>
NF	Noise figure (unmatched configuration)	R <sub>S</sub> = 50Ω, f = 50MHz		9.3		dB
V <sub>IN-EQ</sub>	Equivalent input noise voltage spectral density	f = 100MHz		2.5		nV/√Hz
S12	Reverse isolation	f = 100MHz		-60		dB
ΔG/ΔV <sub>CC</sub>	Gain supply sensitivity (single-ended)			0.3		dB/V
ΔG/ΔT	Gain temperature sensitivity	R <sub>L</sub> = 50Ω		0.013		dB/°C
C <sub>IN</sub>	Input capacitance (single-ended)			2		pF
BW <sub>AGC</sub>	-3dB bandwidth of gain control function			20		MHz
P <sub>O-1dB</sub>	1dB gain compression point at output	f = 100MHz		-3		dBm
P <sub>I-1dB</sub>	1dB gain compression point at input	f = 100MHz, V <sub>AGC</sub> = 0.1V		-10		dBm
IP3 <sub>OUT</sub>	Third-order intercept point at output	f = 100MHz, V <sub>AGC</sub> > 0.5V		+13		dBm
IP3 <sub>IN</sub>	Third-order intercept point at input	f = 100MHz, V <sub>AGC</sub> < 0.5V		+5		dBm
ΔG <sub>AB</sub>	Gain match output A to output B	f = 100MHz, V <sub>AGC</sub> = 1V		0.1		dB

**NOTE:**

1. With R<sub>L</sub> > 1kΩ, overload occurs at input for single-ended gain < 13dB and at output for single-ended gain > 13dB. With R<sub>L</sub> = 50Ω, overload occurs at input for single-ended gain < 6dB and at output for single-ended gain > 6dB.

**SA5219 APPLICATIONS**

The SA5219 is a wideband variable gain amplifier (VGA) circuit which finds many applications in the RF, IF and video signal processing areas. This application note describes the operation of the circuit and several applications of the VGA. The simplified equivalent schematic of the VGA is shown in Figure 2. Transistors Q1-Q6 form the wideband Gilbert multiplier input stage which is biased by current source I1. The top differential pairs are biased from a buffered and level-shifted signal derived from the V<sub>AGC</sub> input and the RF input appears at the lower differential pair. The circuit topology and layout offer low input noise and wide bandwidth. The second stage is a differential transimpedance stage with current feedback which maintains the wide bandwidth of the input stage. The output stage is a pair of emitter followers with 50Ω output impedance. There is also an on-chip bandgap reference with buffered output at 1.3V, which can be used to derive the gain control voltage.

Both the inputs and outputs should be capacitor coupled or DC isolated from the signal sources and loads. Furthermore, the two inputs should be DC isolated from each other and the two outputs should likewise be DC isolated from each other. The SA5219 was designed to provide optimum performance from a 5V power source. However, there is some range around this value (4.5 - 7V) that can be used.

The input impedance is about 1kΩ. The main advantage to a differential input configuration is to provide the balun function.

Otherwise, there is an advantage to common mode rejection, a specification that is not normally important to RF designs. The source impedance can be chosen for two different performance characteristics: Gain, or noise performance. Gain optimization will be realized if the input impedance is matched to about 1kΩ. A 4:1 balun will provide such a broadband match from a 50Ω source. Noise performance will be optimized if the input impedance is matched to about 200Ω. A 2:1 balun will provide such a broadband match from a 50Ω source. The minimum noise figure can then be expected to be about 7dB. Maximum gain will be about 23dB for a single-ended output. If the differential output is used and properly matched, nearly 30dB can be realized. With gain optimization, the noise figure will degrade to about 8dB. With no matching unit at the input, a 9dB noise figure can be expected from a 50Ω source. If the source is terminated, the noise figure will increase to about 15dB. All these noise figures will occur at maximum gain.

The SA5219 has an excellent noise figure vs gain relationship. With any VGA circuit, the noise performance will degrade with decreasing gain. The 5219 has about a 1.2dB noise figure degradation for each 2dB gain reduction. With the input matched for optimum gain, the 8dB noise figure at 23dB gain will degrade to about a 20dB noise figure at 0dB gain.

The SA5219 also displays excellent linearity between voltage gain and control voltage. Indeed, the relationship is of sufficient linearity that high fidelity AM modulation is possible using the SA5219. A

# Wideband variable gain amplifier

# SA5219

maximum control voltage frequency of about 20MHz permits video baseband sources for AM.

A stabilized bandgap reference voltage is made available on the SA5219 (Pin 7). For fixed gain applications this voltage can be resistor divided, and then fed to the gain control terminal (Pin 8). Using the bandgap voltage reference for gain control produces very stable gain characteristics over wide temperature ranges. The gain setting resistors are not part of the RF signal path, and thus stray capacitance here is not important.

The wide bandwidth and excellent gain control linearity make the SA5219 VGA ideally suited for the automatic gain control (AGC) function in RF and IF processing in cellular radio base stations, Direct Broadcast Satellite (DBS) decoders, cable TV systems, fiber optic receivers for wideband data and video, and other radio communication applications. A typical AGC configuration using the SA5219 is shown in Figure 3. Three SA5219s are cascaded with appropriate AC coupling capacitors. The output of the final stage drives the full-wave rectifier composed of two UHF Schottky diodes

BAT17 as shown. The diodes are biased by R1 and R2 to  $V_{CC}$  such that a quiescent current of about 2mA in each leg is achieved. An SA5230 low voltage op amp is used as an integrator which drives the  $V_{AGC}$  pin on all three SA5219s. R3 and C3 filter the high frequency ripple from the full-wave rectified signal. A voltage divider is used to generate the reference for the non-inverting input of the op amp at about 1.7V. Keeping D3 the same type as D1 and D2 will provide a first order compensation for the change in Schottky voltage over the operating temperature range and improve the AGC performance. R6 is a variable resistor for adjustments to the op amp reference voltage. In low cost and large volume applications this could be replaced with a fixed resistor, which would result in a slight loss of the AGC dynamic range. Cascading three SA5219s will give a dynamic range in excess of 60dB.

The SA5219 is a very user-friendly part and will not oscillate in most applications. However, in an application such as with gains in excess of 60dB and bandwidth beyond 100MHz, good PC board layout with proper supply decoupling is strongly recommended.

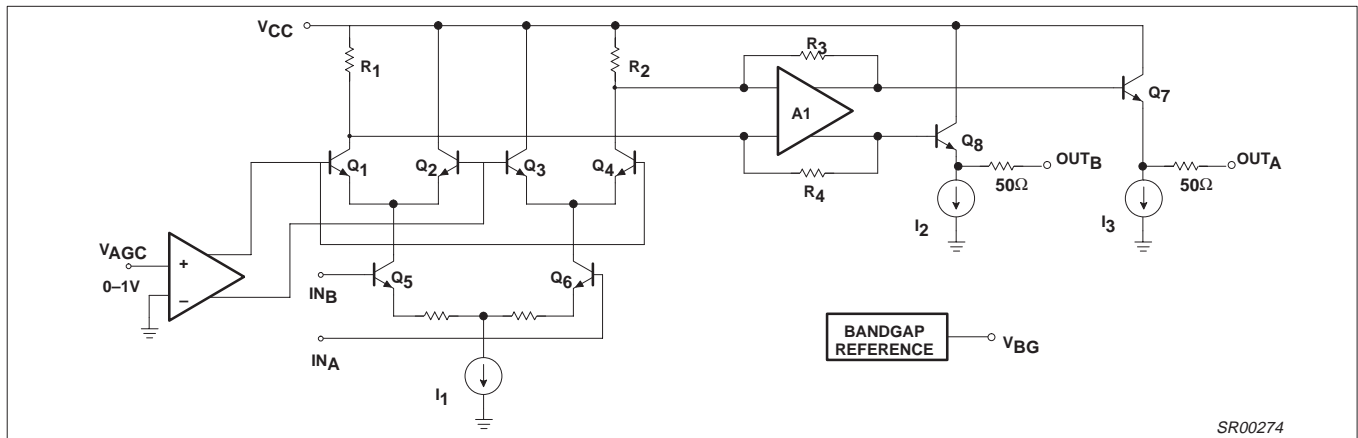

Figure 2. Equivalent Schematic of VGA

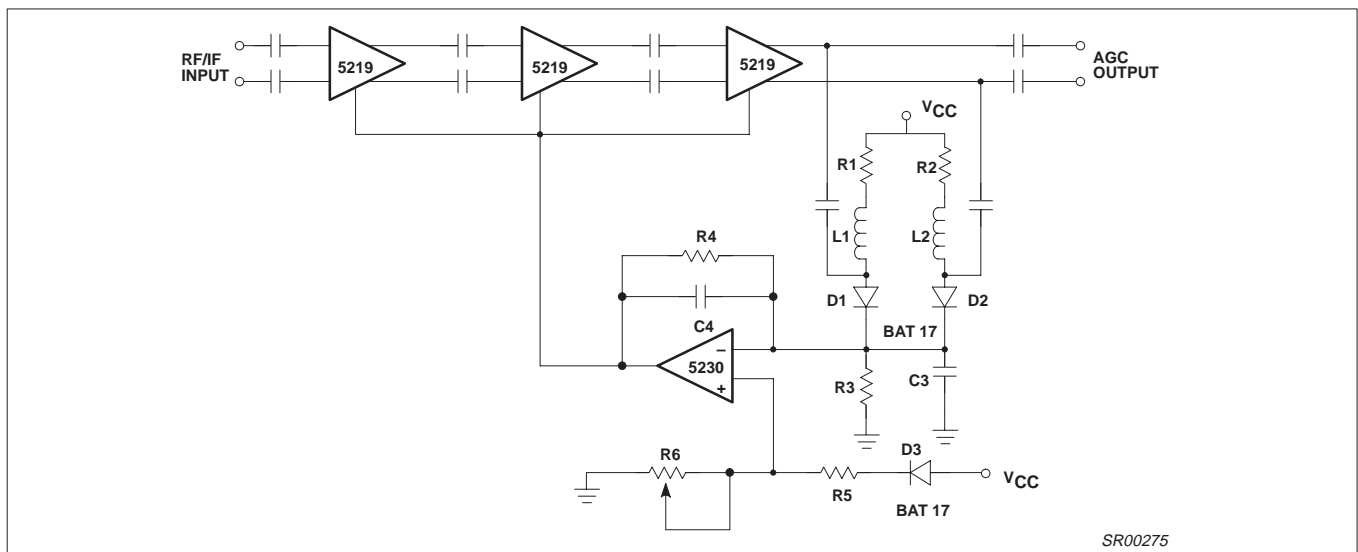

Figure 3. AGC Configuration Using Cascaded SA5219s

# Wideband variable gain amplifier

# SA5219

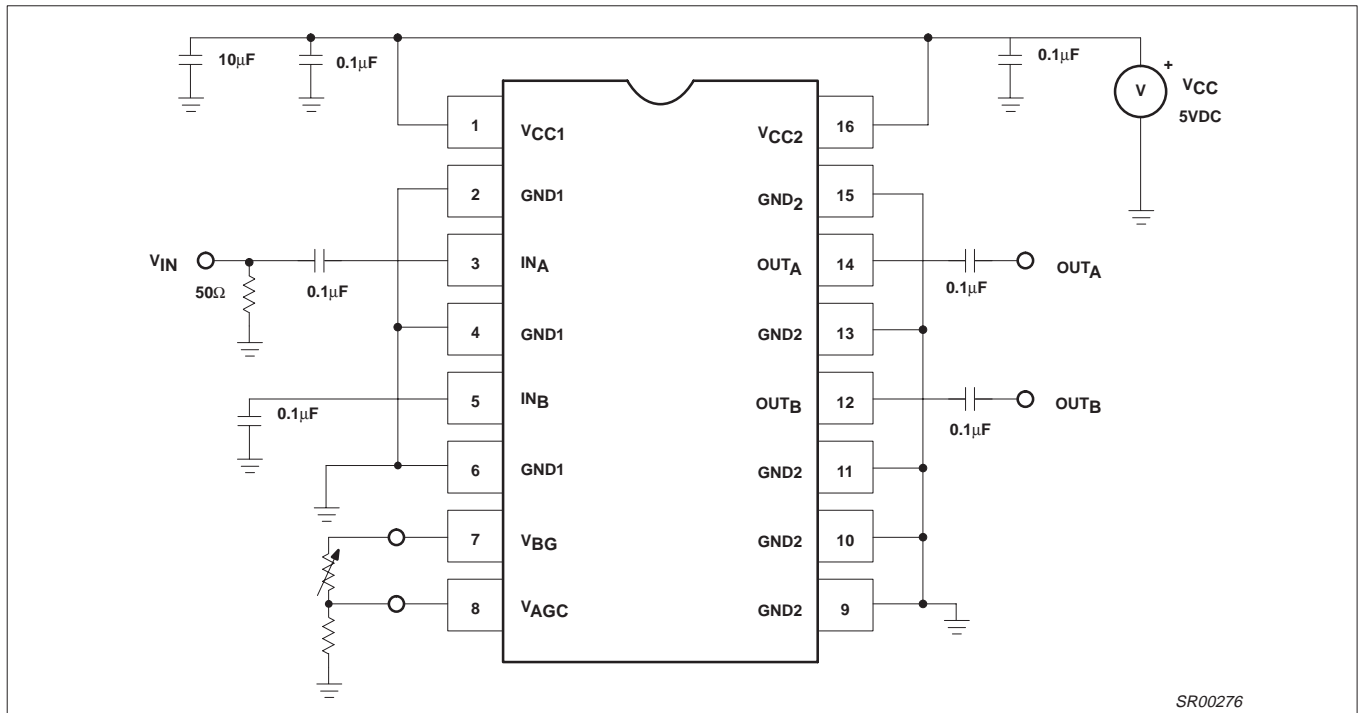

Figure 4. VGA AC Evaluation Board

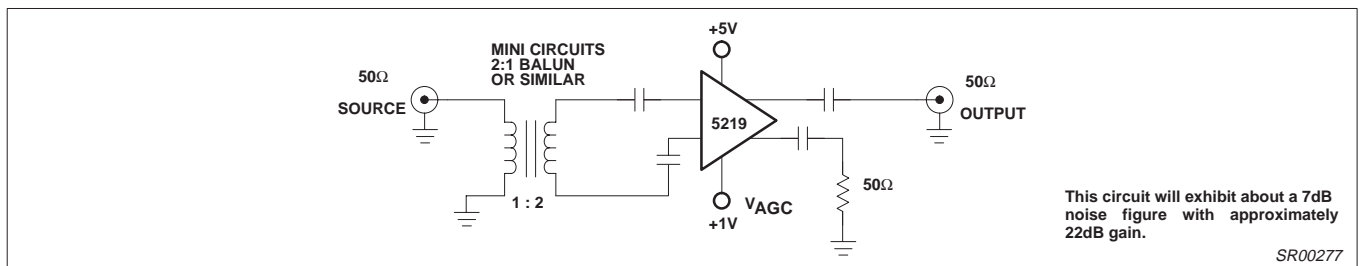

Figure 5. Broadband Noise Optimization

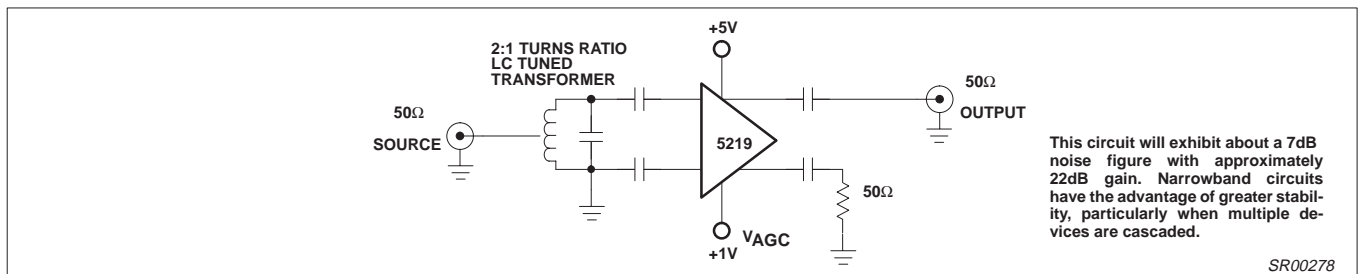

Figure 6. Narrowband Noise Optimization

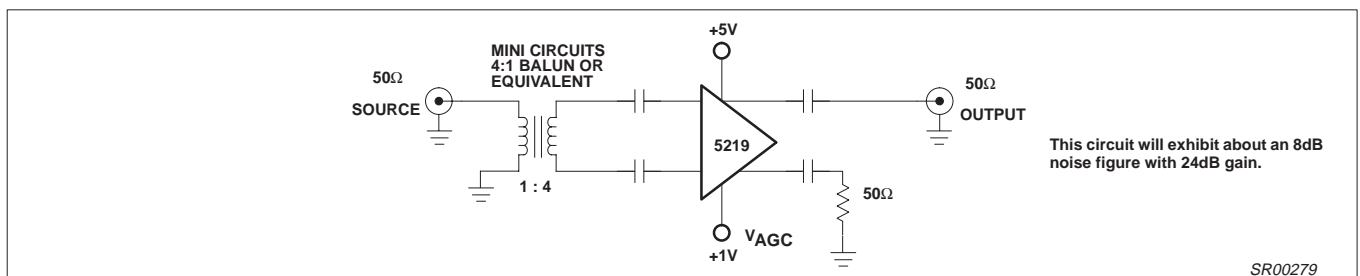

Figure 7. Broadband Gain Optimization

# Wideband variable gain amplifier

# SA5219

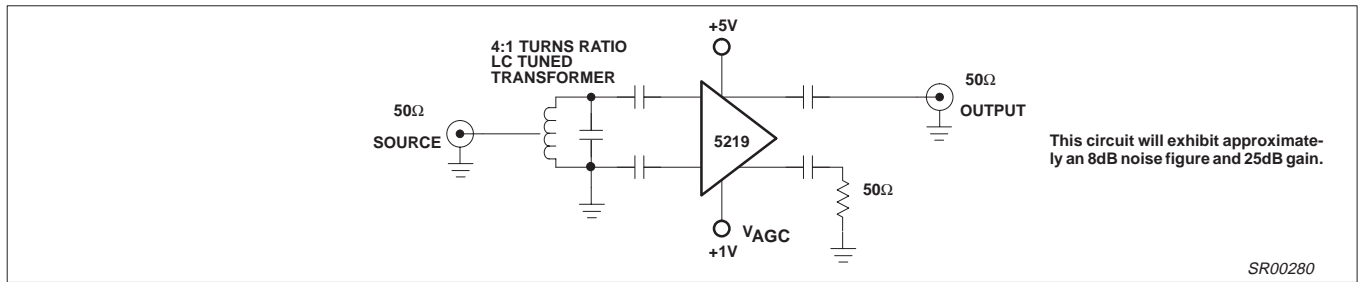

Figure 8. Narrowband Gain Optimization

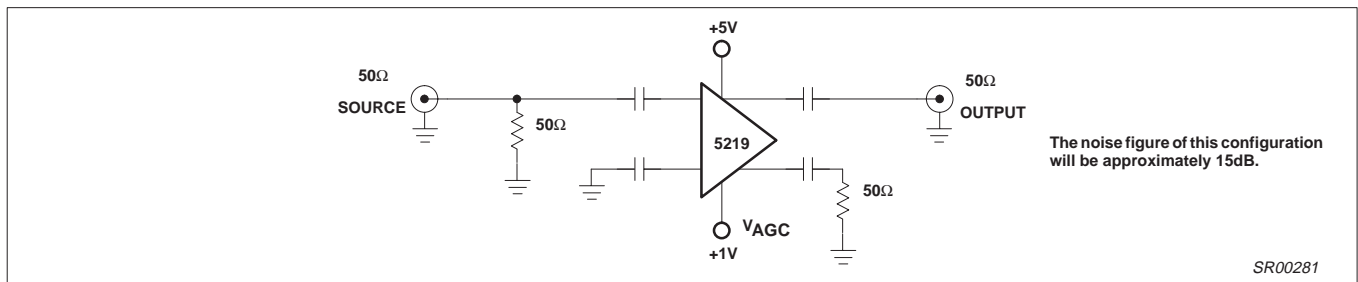

Figure 9. Simple Amplifier Configuration

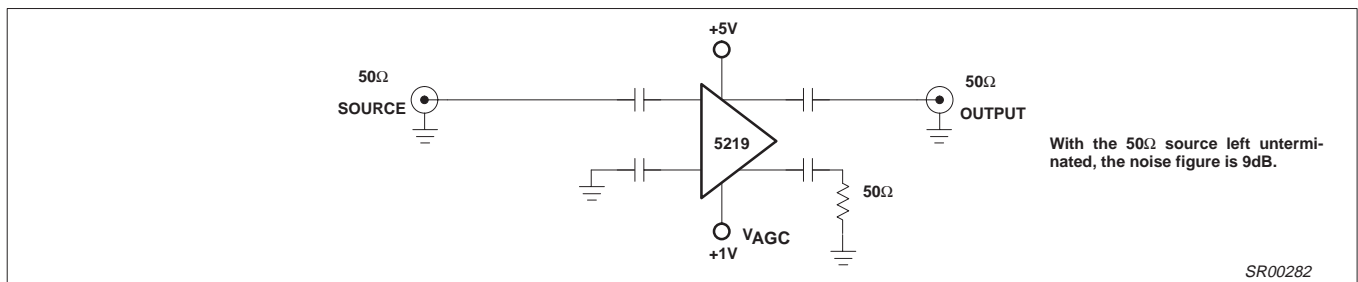

Figure 10. Underterminated Configuration

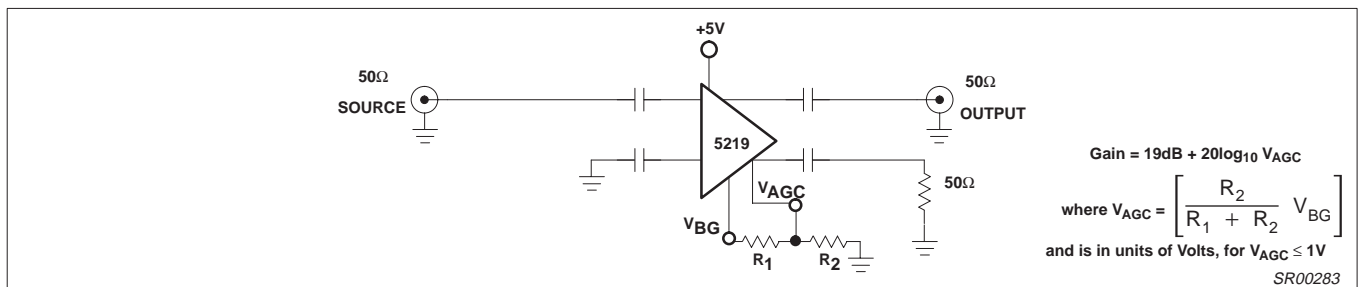

Figure 11. User-Programmable Fixed Gain Block

# Wideband variable gain amplifier

# SA5219

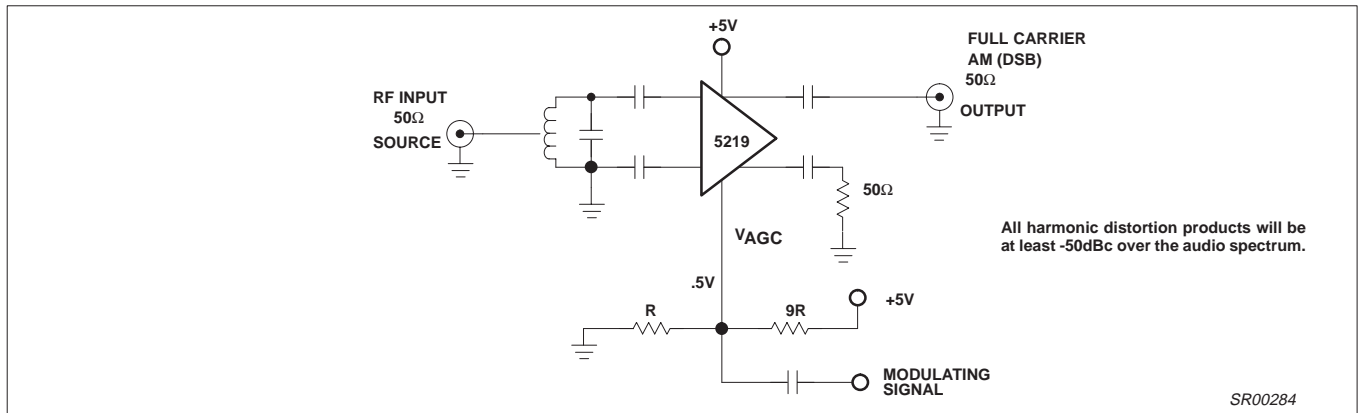

Figure 12. AM Modulator

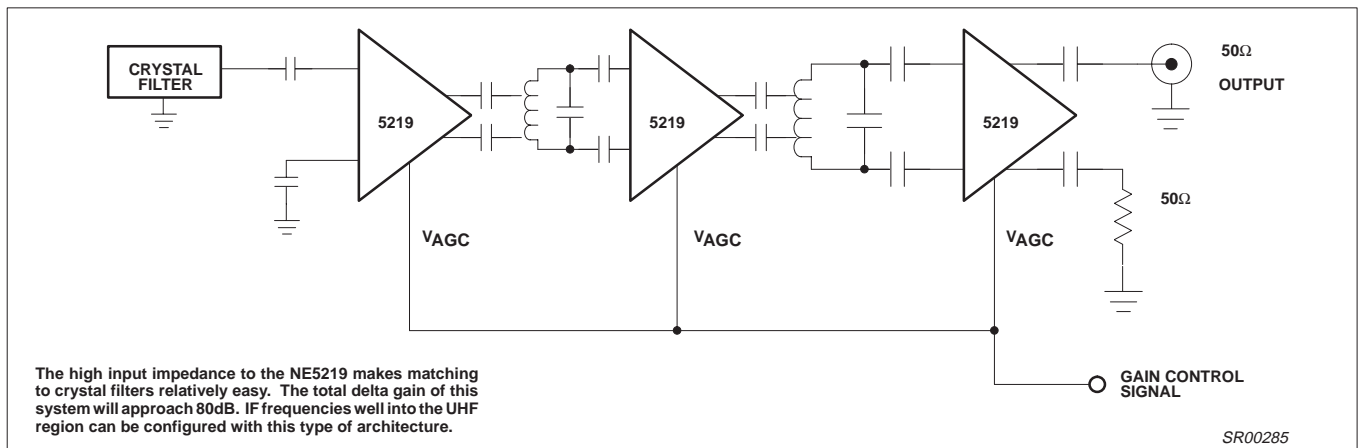

Figure 13. Receiver AGC IF Gain

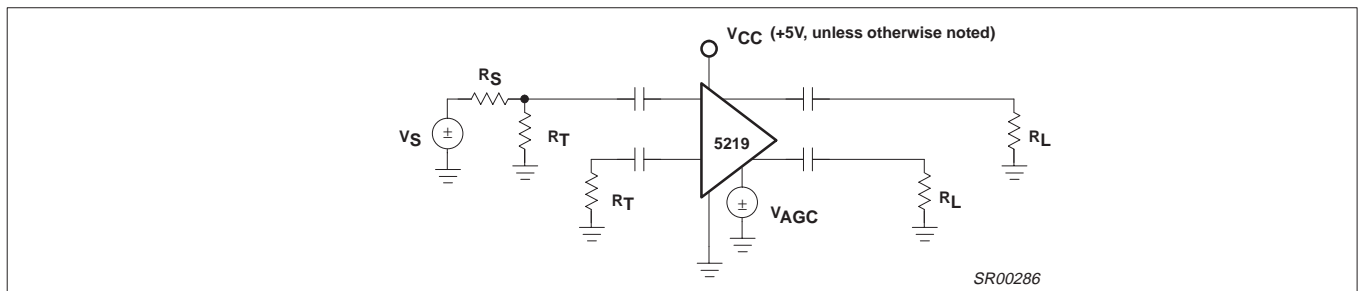

Figure 14. Test Set-up 1 (Used for all Graphs)



Wideband variable gain amplifier

SA5219

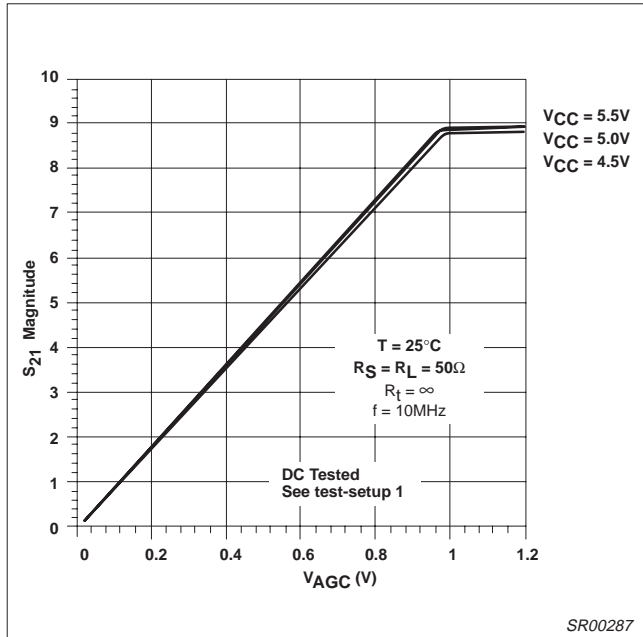

Figure 15. Gain vs  $V_{AGC}$  and  $V_{CC}$

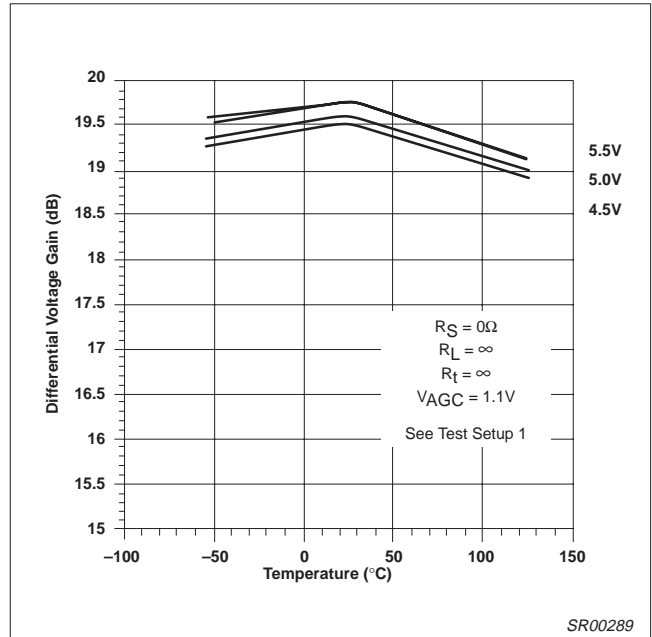

Figure 17. Voltage Gain vs Temperature and  $V_{CC}$

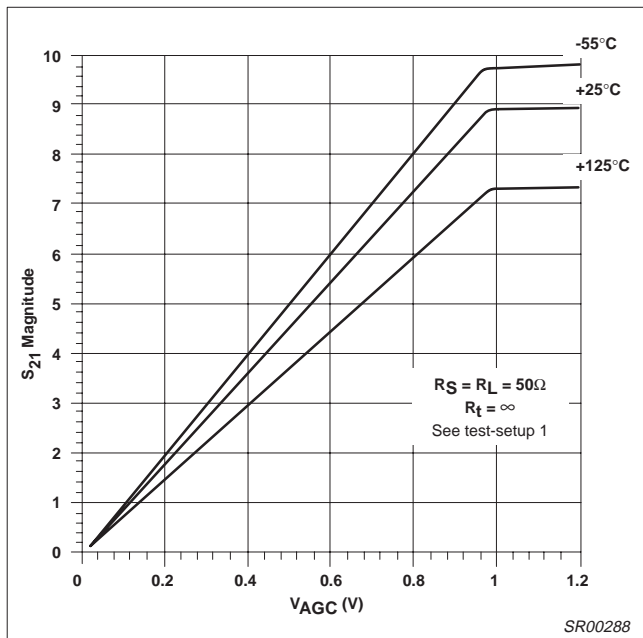

Figure 16. Insertion Gain vs  $V_{AGC}$  and Temperature

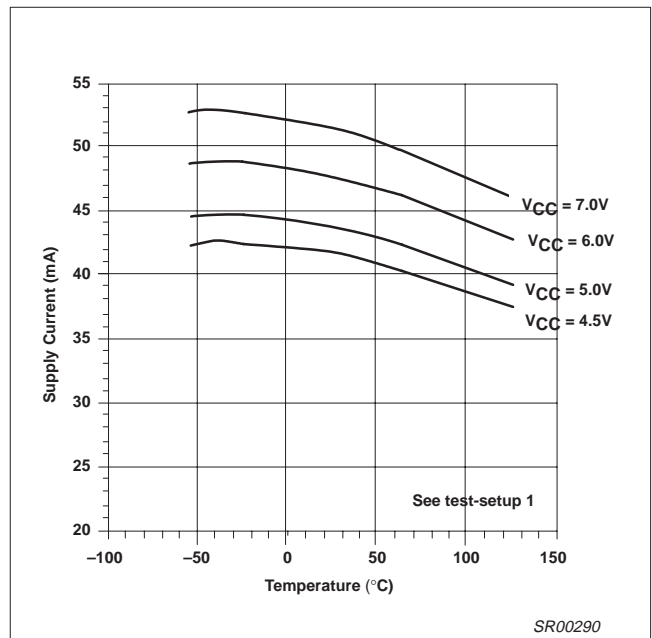

Figure 18. Supply Current vs Temperature and  $V_{CC}$

# Wideband variable gain amplifier

# SA5219

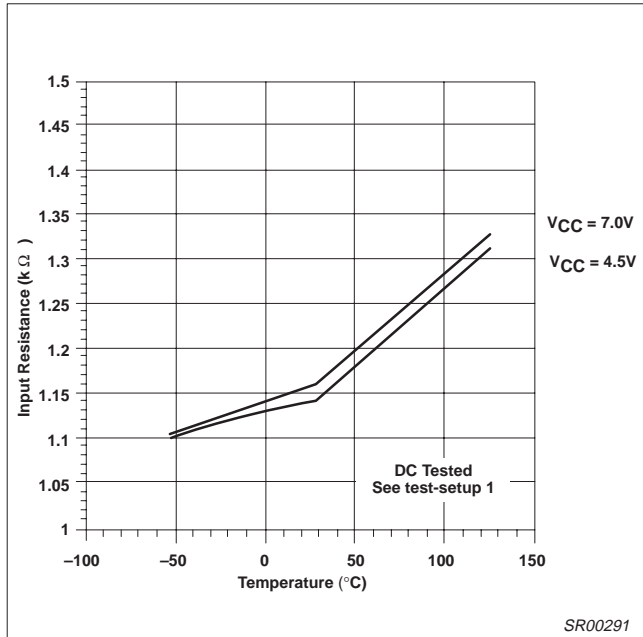

Figure 19. Input Resistance vs Temperature

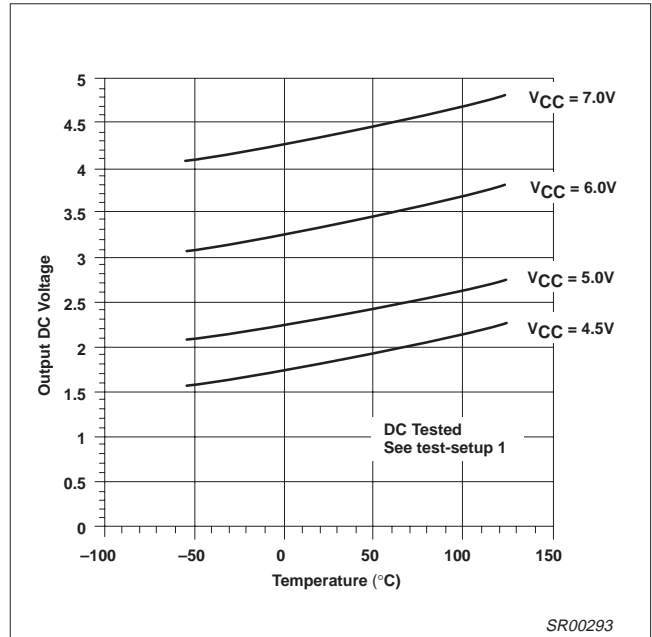

Figure 21. Output Bias Voltage vs Temperature and VCC

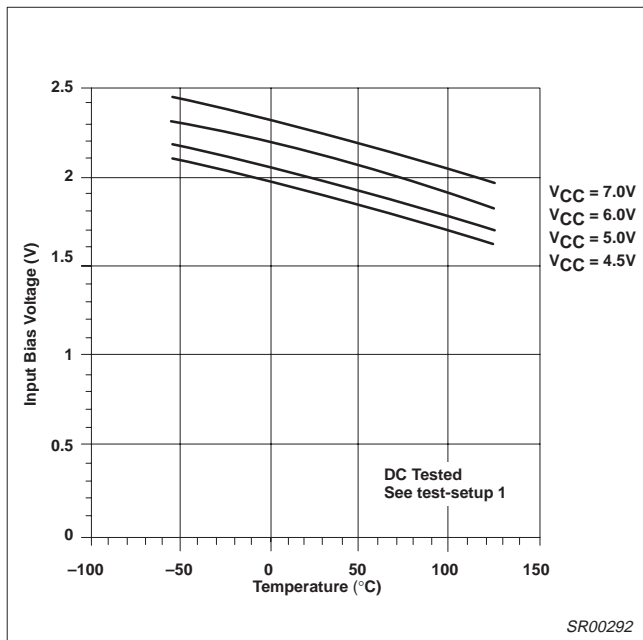

Figure 20. Input Bias Voltage vs Temperature

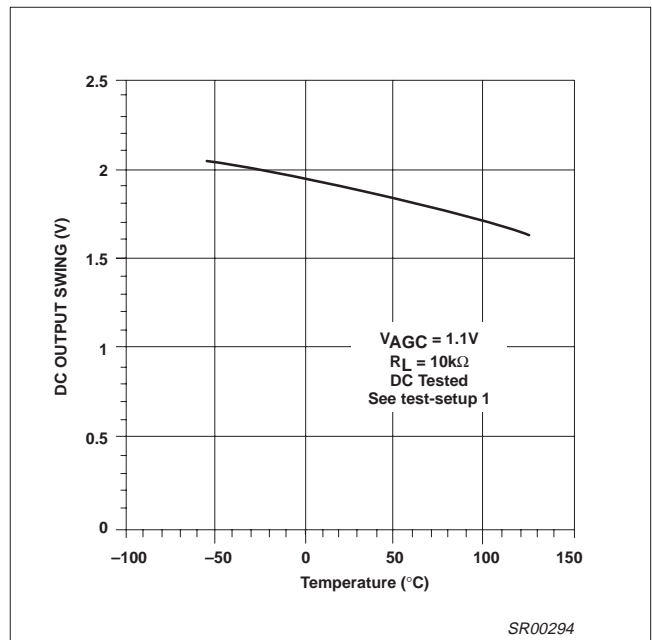

Figure 22. DC Output Swing vs Temperature

Wideband variable gain amplifier

SA5219

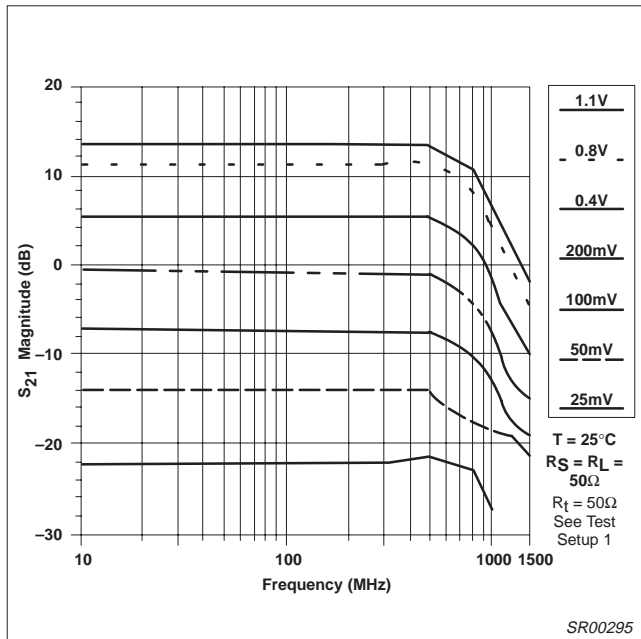

Figure 23. Insertion Gain vs Frequency and  $V_{AGC}$

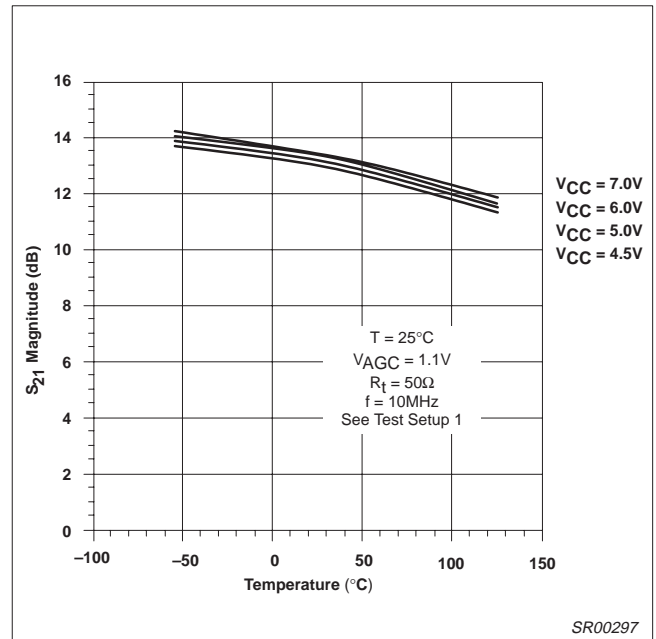

Figure 25. Insertion Gain vs Temperature and  $V_{CC}$

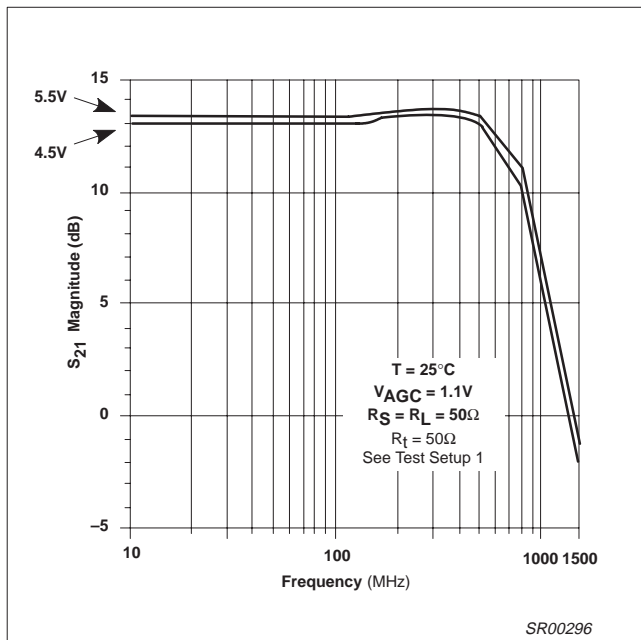

Figure 24. Insertion Gain vs Frequency and  $V_{CC}$

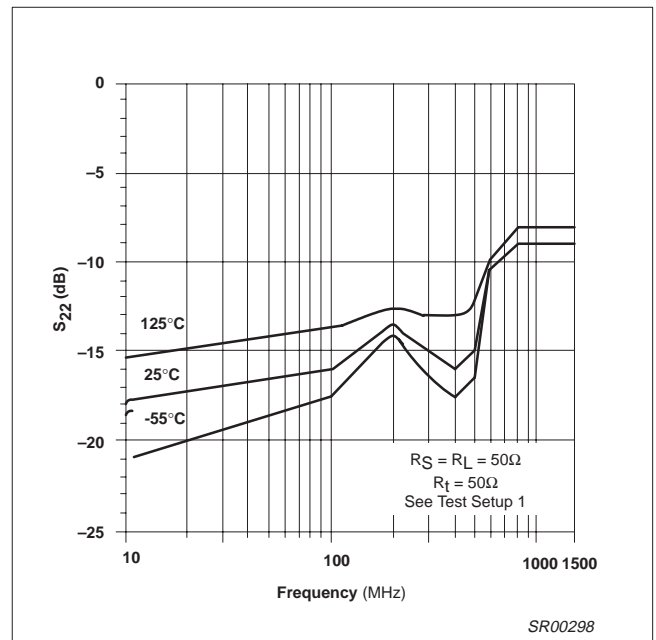

Figure 26. Output Return Loss vs Frequency

Wideband variable gain amplifier

SA5219

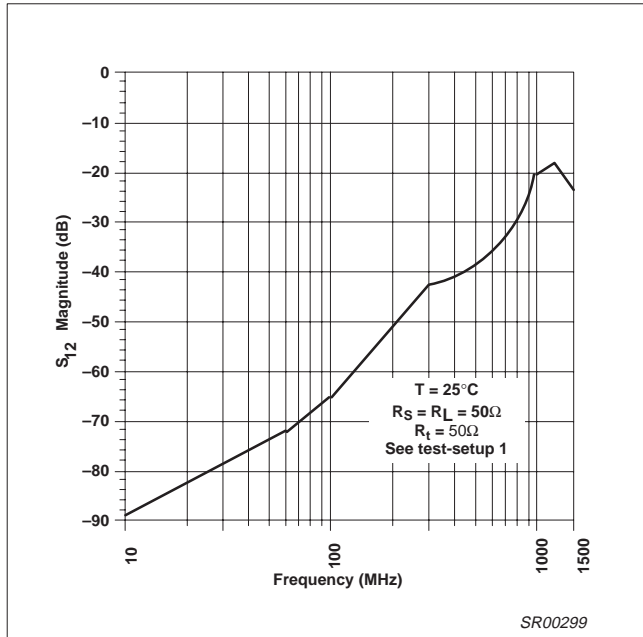

Figure 27. Reverse Isolation vs Frequency

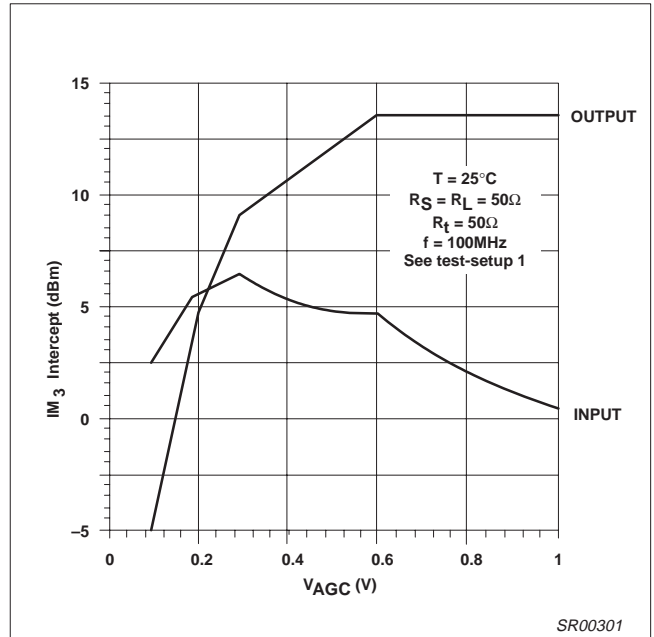

Figure 29. Third-Order Intermodulation Intercept vs  $V_{AGC}$

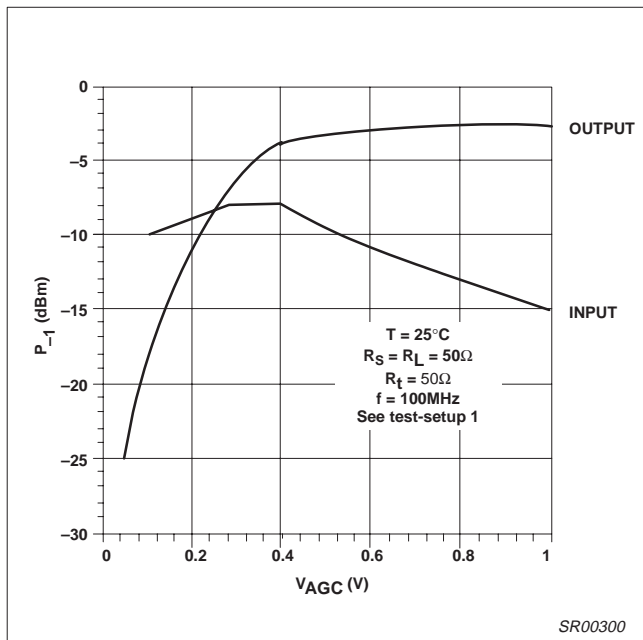

Figure 28. 1dB Gain Compression vs  $V_{AGC}$

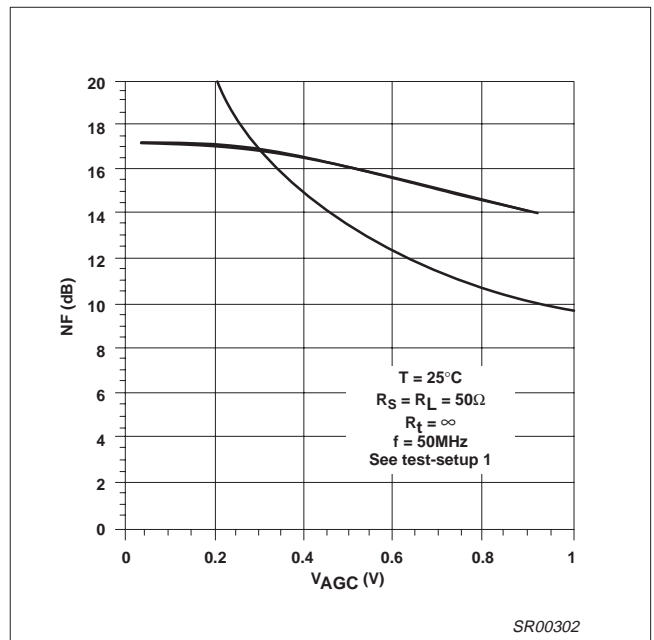

Figure 30. Noise Figure vs  $V_{AGC}$

Wideband variable gain amplifier

SA5219

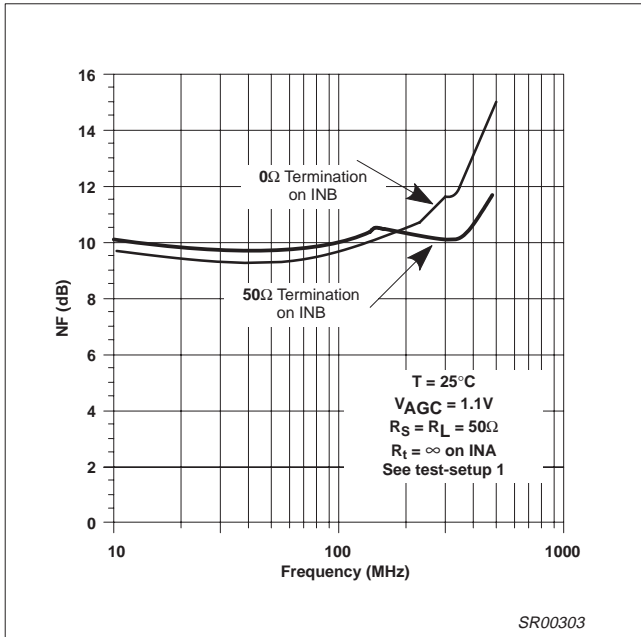

Figure 31. Noise Figure vs Frequency

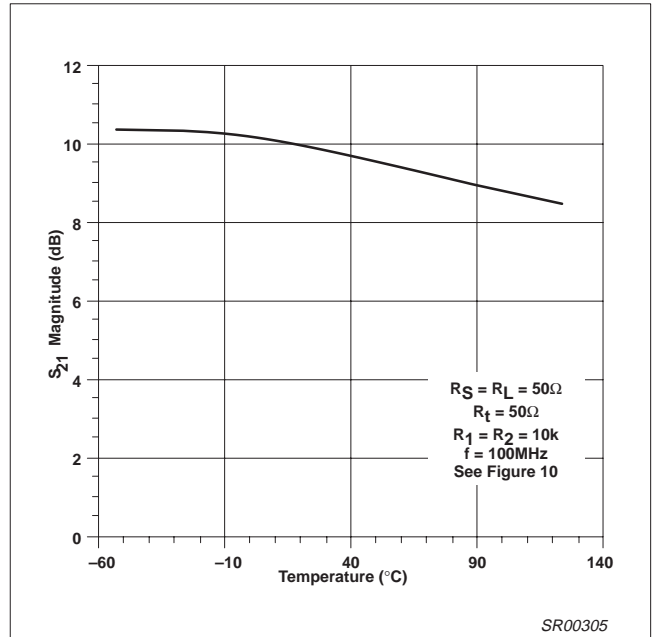

Figure 33. Fixed Gain vs Temperature

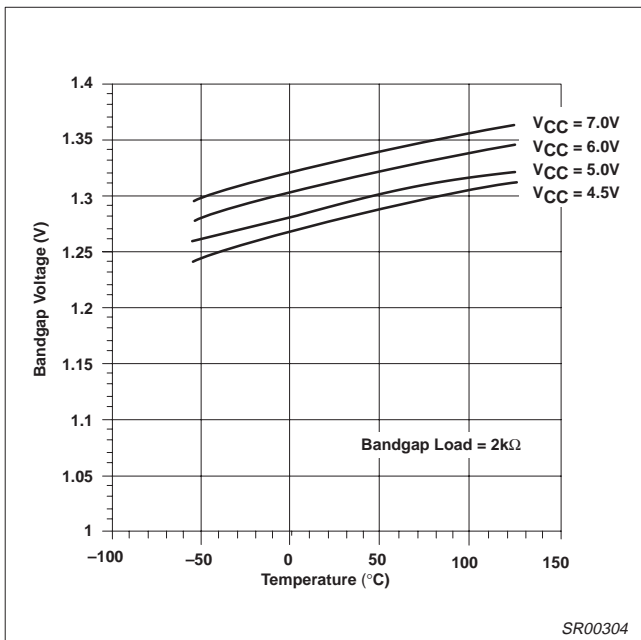

Figure 32. Bandgap Voltage vs Temperature and VCC

# Wideband variable gain amplifier

## SA5219

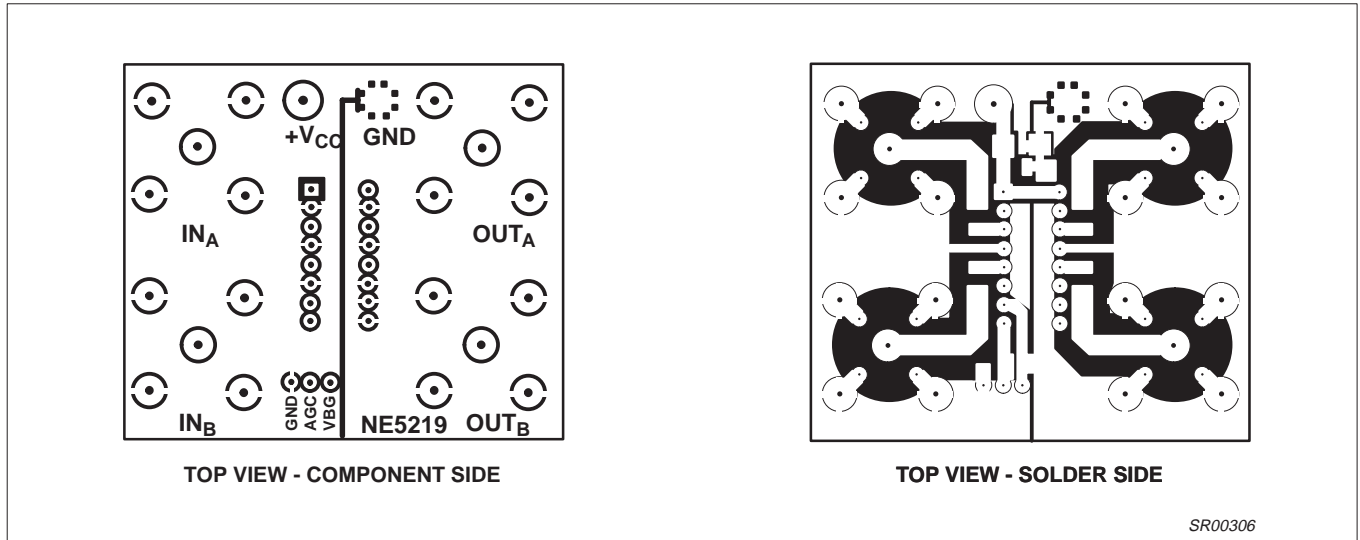

Figure 34. VGA AC Evaluation Board Layout (DIP Package)

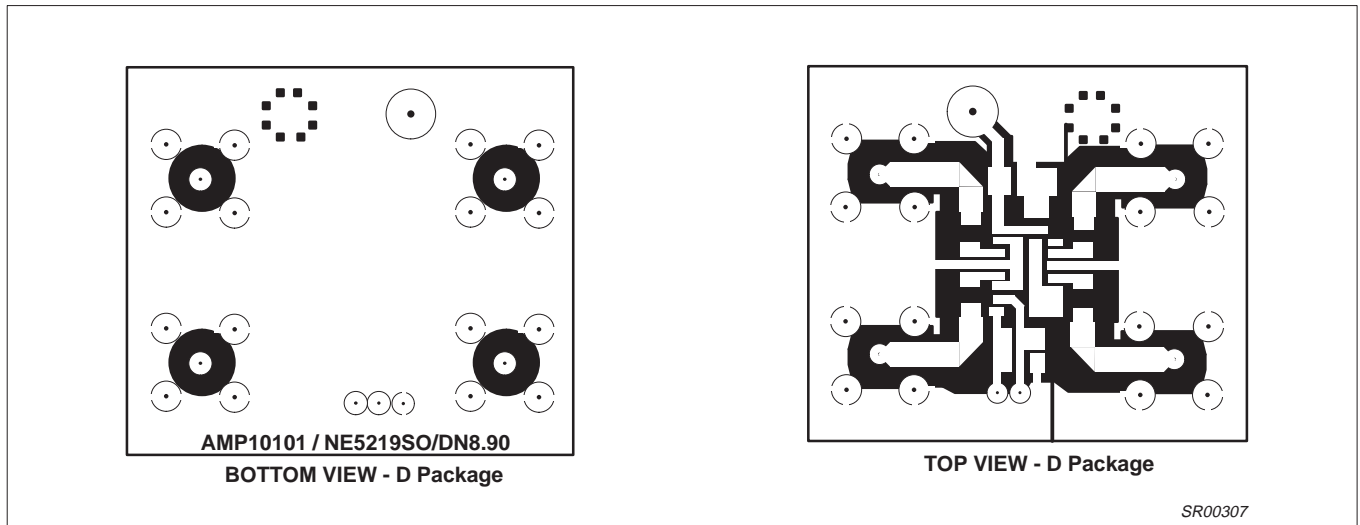

Figure 35. VGA AC Evaluation Board Layout (SO Package)

# Wideband variable gain amplifier

## SA5219

DIP16: plastic dual in-line package; 16 leads (300 mil)

SOT38-4



**DIMENSIONS (inch dimensions are derived from the original mm dimensions)**

UNIT	A max.	A <sub>1</sub> min.	A <sub>2</sub> max.	b	b <sub>1</sub>	b <sub>2</sub>	c	D <sup>(1)</sup>	E <sup>(1)</sup>	e	e <sub>1</sub>	L	M <sub>E</sub>	M <sub>H</sub>	w	Z <sup>(1)</sup> max.
mm	4.2	0.51	3.2	1.73 1.30	0.53 0.38	1.25 0.85	0.36 0.23	19.50 18.55	6.48 6.20	2.54	7.62	3.60 3.05	8.25 7.80	10.0 8.3	0.254	0.76
inches	0.17	0.020	0.13	0.068 0.051	0.021 0.015	0.049 0.033	0.014 0.009	0.77 0.73	0.26 0.24	0.10	0.30	0.14 0.12	0.32 0.31	0.39 0.33	0.01	0.030

**Note**

1. Plastic or metal protrusions of 0.25 mm maximum per side are not included.

OUTLINE VERSION	REFERENCES				EUROPEAN PROJECTION	ISSUE DATE
	IEC	JEDEC	EIAJ			
SOT38-4						92-11-17 95-01-14

# Wideband variable gain amplifier

# SA5219

**SO16: plastic small outline package; 16 leads; body width 3.9 mm**

**SOT109-1**

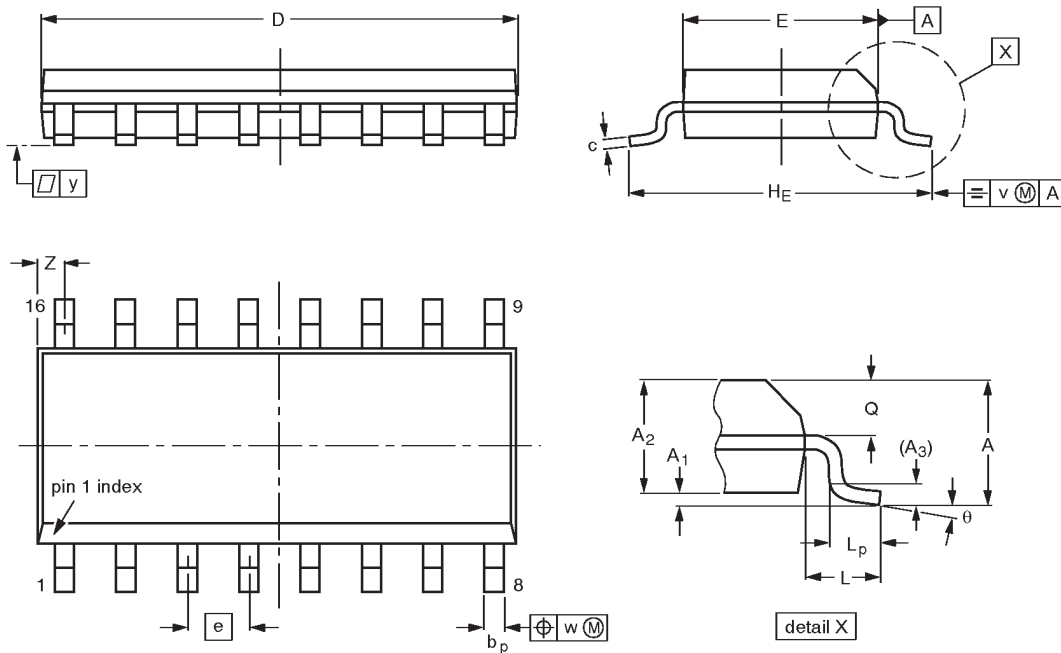

**DIMENSIONS (inch dimensions are derived from the original mm dimensions)**

UNIT	A max.	A <sub>1</sub>	A <sub>2</sub>	A <sub>3</sub>	b <sub>p</sub>	c	D <sup>(1)</sup>	E <sup>(1)</sup>	e	H <sub>E</sub>	L	L <sub>p</sub>	Q	v	w	y	Z <sup>(1)</sup>	θ
mm	1.75	0.25 0.10	1.45 1.25	0.25	0.49 0.36	0.25 0.19	10.0 9.8	4.0 3.8	1.27	6.2 5.8	1.05	1.0 0.4	0.7 0.6	0.25	0.25	0.1	0.7 0.3	8° 0°
inches	0.069	0.0098 0.0039	0.057 0.049	0.01	0.019 0.014	0.0098 0.0075	0.39 0.38	0.16 0.15	0.050	0.24 0.23	0.041	0.039 0.016	0.028 0.020	0.01	0.01	0.004	0.028 0.012	

**Note**

1. Plastic or metal protrusions of 0.15 mm maximum per side are not included.

OUTLINE VERSION	REFERENCES				EUROPEAN PROJECTION	ISSUE DATE
	IEC	JEDEC	EIAJ			
SOT109-1	076E07S	MS-012AC				91-08-13 95-01-23



---

Wideband variable gain amplifier

SA5219

---

**NOTES**

## Wideband variable gain amplifier

SA5219

## DEFINITIONS

Data Sheet Identification	Product Status	Definition
<i>Objective Specification</i>	<b>Formative or in Design</b>	This data sheet contains the design target or goal specifications for product development. Specifications may change in any manner without notice.
<i>Preliminary Specification</i>	<b>Preproduction Product</b>	This data sheet contains preliminary data, and supplementary data will be published at a later date. Philips Semiconductors reserves the right to make changes at any time without notice in order to improve design and supply the best possible product.
<i>Product Specification</i>	<b>Full Production</b>	This data sheet contains Final Specifications. Philips Semiconductors reserves the right to make changes at any time without notice, in order to improve design and supply the best possible product.

Philips Semiconductors and Philips Electronics North America Corporation reserve the right to make changes, without notice, in the products, including circuits, standard cells, and/or software, described or contained herein in order to improve design and/or performance. Philips Semiconductors assumes no responsibility or liability for the use of any of these products, conveys no license or title under any patent, copyright, or mask work right to these products, and makes no representations or warranties that these products are free from patent, copyright, or mask work right infringement, unless otherwise specified. Applications that are described herein for any of these products are for illustrative purposes only. Philips Semiconductors makes no representation or warranty that such applications will be suitable for the specified use without further testing or modification.

## LIFE SUPPORT APPLICATIONS

Philips Semiconductors and Philips Electronics North America Corporation Products are not designed for use in life support appliances, devices, or systems where malfunction of a Philips Semiconductors and Philips Electronics North America Corporation Product can reasonably be expected to result in a personal injury. Philips Semiconductors and Philips Electronics North America Corporation customers using or selling Philips Semiconductors and Philips Electronics North America Corporation Products for use in such applications do so at their own risk and agree to fully indemnify Philips Semiconductors and Philips Electronics North America Corporation for any damages resulting from such improper use or sale.

**Philips Semiconductors**  
**811 East Arques Avenue**  
**P.O. Box 3409**  
**Sunnyvale, California 94088-3409**  
**Telephone 800-234-7381**

© Copyright Philips Electronics North America Corporation 1997  
 All rights reserved. Printed in U.S.A.

*Let's make things better.*